

Commercial Vehicle Pre-Trip Inspection Checklist

The Commercial Vehicle Pre-Trip Inspection Test is designed to test your ability to check a variety of commercial vehicle safety equipment and vehicle components. You are required to check the items listed below that relate to the operation of your vehicle. You will need to point out the item to be checked and explain how you check that item. You may use this checklist during your pre-trip inspection.

All commercial vehicles must display a current inspection sticker to receive a road test.

Combination Vehicle Type

| | | | |
|---|---|--|---|
| Truck Air & electric connectors Coupling System mounting bolts pintle hook hitch release lever safety devices | Trailer Air & electric connectors Tongue storage area Coupling System tongue or drawbar mounting bolts safety devices sliding pintle | Tractor Air & electric connectors Coupling System mounting bolts platform locking jaws or lever release arm & safety latch 5th wheel skid plate slide 5th wheel pins | Semi-Trailer Air & electric connectors Coupling System kingpin apron gap |
|---|---|--|---|

All Vehicles

| | | |
|---|---|---|
| Front of Vehicle lights & reflectors mirrors Engine Compartment oil level coolant level power steering fluid water pump alternator leaks & hoses <i>*air compressor</i> <i>master cylinder</i> automatic transmission fluid Steering steering box & hoses steering linkage Front Wheel tires rims lug nuts hub oil seal Front Suspension springs & shocks u-bolts spring mounts Front Brake brake hoses or line <i>*brake chamber</i> <i>*slack adjuster & push-rod</i> drum & linings or rotor & disk | Driver/Fuel Area door & mirror fuel tank & cap & leaks catwalk & steps battery/box lights & reflectors Under Vehicle drive shaft exhaust system frame Rear Axles tires rims lug nuts hub oil seal spacers or budd spacing Rear Suspension springs & shocks & airbags u-bolts spring/air mounts Rear Brakes brake hoses or lines <i>*brake chamber</i> <i>*slack adjuster & push-rod</i> drum & linings or rotor & disk Rear of Vehicle doors & lift splash guards lights & reflectors | Combination Vehicles Trailer Front header board or bulkhead lights & reflectors Side of Trailer landing gear frame & tandem release doors & ties & lifts lights & reflectors Trailer Wheels tires rims lug nuts hub oil seal spacers or budd spacing Trailer Suspension springs & shocks & airbags u-bolts spring/air mounts Trailer Brakes brake hoses or line <i>*brake chamber</i> <i>*slack adjuster & push-rod</i> drum & linings or rotor & disk Rear of Trailer doors & lift - Loading Ramps splash guards lights & reflectors |
|---|---|---|

***CHECK LIGHTS! (All 7)**

Passenger Bus Vehicles

| | | | |
|------------------------|-----------------|---------|----------------------|
| Passenger entry & lift | Emergency exits | Seating | Baggage doors secure |
|------------------------|-----------------|---------|----------------------|

School Buses

| | | | |
|---------------|---------------|----------------|----------------------|
| 8 Lamp system | First aid kit | Body fluid kit | Emergency exit types |
|---------------|---------------|----------------|----------------------|

Inside Vehicles

| | | | |
|---|--|---|---|
| Safety belt Emergency equipment Safe start Temperature gauge | Oil pressure gauge Ammeter or voltmeter gauge <i>*Air gauge</i> Lighting indicators | Horn(s) Heater & defroster Windshield & mirrors Wipers & washers | Parking brake Service brake <i>*Air brake check</i> Hydraulic brake Check/electric assist |
|---|--|---|---|

***Air brake system only.**

THINGS TO REMEMBER

1. **DO NOT** hit a curb with the trailer during a right hand turn.
2. **DO NOT** roll at stop signs. Make a complete stop.
3. Look both directions at all intersections, both controlled and uncontrolled intersections.
4. When parking on a hill next to a curb:

UPHILL – TURN steering wheel left

DOWNHILL – TURN steering wheel right

Signal when moving towards curb and when leaving curb.

5. All roads on the exam station course are considered 4 lanes wide, whether they are marked with lines or not. 2 lanes in each direction.

6. The 2 lanes on your half **DO NOT** turn the same direction. No double turns in the course.

7. Watch posted speed limits outside of course. Do not speed.

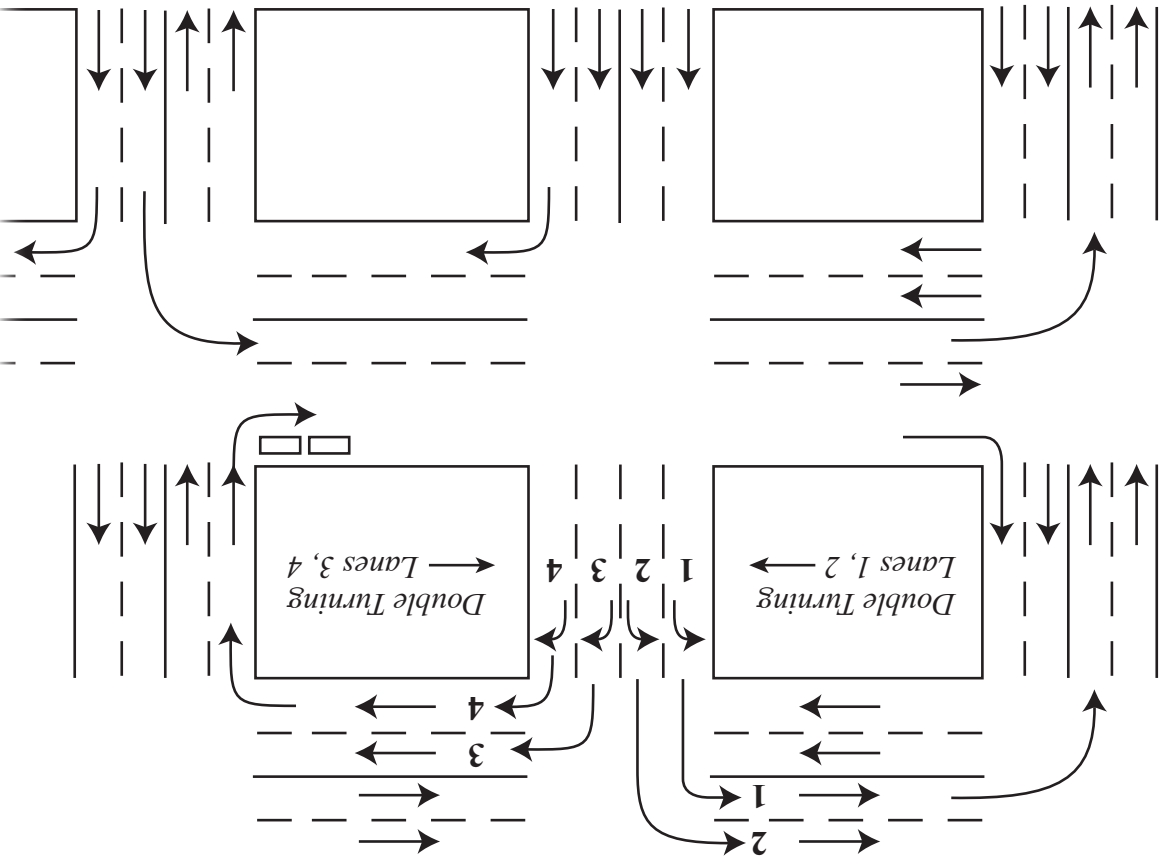

Tractor

- air and electric connectors and lines
 - electrical cord firmly plugged in and secured, no tears/cuts or exposed wires, not dragging on the frame and with enough slack for turns. Green latch is not missing on electrical connection.
 - air lines properly connected to glad hands, no air leaks, no tears/cuts and enough slack for turns. No missing or torn rubber seals.

Coupling System

- mounting bolts
 - check for loose or missing bolts and nuts, cracked bolts and shiny threading.
- platform
 - secured to frame, no cracks, not bent or warped, missing bolts and nuts.
- locking jaws
 - locking jaws around the “shank”, and not the “head” of the kingpin, latched secured and visible. Not bent or cracked. Properly greased.
- release arm
 - release arm properly seated and safety latch/lock engaged and secured, no cracks or bent arm. Proper spring tension.
- 5th wheel skid plate
 - greased/lubed, (poly plate) mounted secured, no cracks. Not bent or warped.

Semi-Trailer

- Air and electric connectors
 - electrical cord firmly plugged in and secured, no tears, cuts or exposed wires, not dragging on the frame and with enough slack for turns.
 - Air lines properly connected, no air leaks, no tears or cuts and enough slack for turns.

Coupling System

- kingpin
 - locked in jaws, not bent or cracked. “Head” visible under the locking jaws.
- Apron
 - not bent or cracked, secured to trailer frame. No broken welds.
- Gap
 - check for space or gaps between apron and 5th wheel, which could potentially indicate that the kingpin is not properly locked.

CLASS A LEASING

Truck – Trailer Rental
Class A or Class B CDL Road Test

www.CLASSALEASING.com

(612) 723-4398

Front of Vehicle

Lights & reflectors: Wires are connected. Lights are not cracked, broken, or loose; not missing; are clean and proper color. Reflectors are not cracked, broken, or loose; not missing; are clean; not covered.

Mirrors: Not cracked, broken, or loose; mounted securely. No loose bolts/nuts, cracks in the frame/arm. Not dirty or missing.

Engine Compartment

Oil level: (You do not have to actually check any fluid level, but be able to explain the process.)
Yellow dipstick - should be above the add mark (while engine is off.)

Coolant level: Should be above the add mark. Reservoir mounted securely, hose fitting tight with no leaking fluid, etc. Wires not cut.

Power steering level: Should be above the minimum/add mark (checked while engine is running on automatic only.)
Not leaking.

Water pump: Not cracked, leaking; proper belt tension (3/4 inch). (You do not have to actually check the belt tension; just say you would.) Belt condition: no tears or cut; securely mounted.

Alternator: No loose or missing bolts. No cracked or exposed wires. Proper belt tension (3/4 inch.) Securely mounted.

Leaks & hoses: Look for leaks or puddles under the engine compartment. Hoses should not be cracked, broken, or loose; not leaking.

Air compressor: Not cracked, broken, or loose, no missing bolts; not leaking; securely mounted.
Proper belt tension (3/4 inch on automatic only). Manual is gear driven.

Automatic transmission: Red dipstick - Should be above the add mark (while the engine is running.)

Steering:

Steering box & hoses: (At bottom of the steering column) Steering box is securely mounted; not cracked, broken, or loose; no missing bolts or cotter keys; not leaking. Hoses are not cracked, broken, or loose; not leaking.

Steering linkage: Not cracked, broken, or loose; no missing bolts. Same for all linkage points. Linkage joints greased. Castle nuts are not missing pins or cotter keys. Check for excessive play in steering shaft.

Front Wheel

Tires: 4/32 min. tread depth; not uneven/unevenly worn; no cracks, cuts, or bulging in sidewall. Check proper inflation with a tire gauge or mallet. Valve stem not cracked or cap missing.

Rims: Not bent, cracked, or welded. Not warped.

Lug nuts: Not cracked, missing, or loose (no gaps, shiny threads, or rust trails).

Hub oil seal: Not cracked, or leaking; no loose or missing nuts; proper level above the add mark.

Front Suspension

Springs & Shocks: No cracked, broken, or loose springs; not cracked, bent, or loose; no leaking shocks. No torn bushings on shocks.

U-bolts: Not cracked, bent, or broken; no loose or missing u-bolts; no missing nuts.

Spring mounts: Not bent, cracked, or broken; no loose mounts, or missing bolts. No torn bushings.

Front Brake

Brake hoses or lines: Not cracked, worn, or leaking air hoses; fittings are tight. Lines are not cracked, loose, or rubbing on anything. Look for exposed or corroded wires.

Brake chamber: Not cracked, dented, or loose; mounted securely; no missing bolts or broken c-clamps; not leaking air.

Slack adjustor: Not bent or cracked; no missing pins or cotter keys; greased.

Push-rod: No more than 1 inch of play when you pull by hand. Also, not bent or cracked.

Drums: No warped, cracked, or welded drums. No grease or oil.
Look through inspection hole (automatic only): linings are not cracked; no grease or oil on them; evenly worn.

Linings: Linings (shoes) are at least 1/4 inch thick, evenly worn.

Driver/Fuel Area

| | |
|--------------------------|---|
| Door: | Door has no missing seals; no bent or loose hinges; latches securely. Handles from outside/inside open the door. |
| Mirror: | Mirror is not cracked, broken, or loose; mounted securely. |
| Fuel tank & cap & leaks: | Not cracked or leaking; no broken or loose straps; no cracked or missing cap. Gasket seal inside not ripped or torn. |
| Steps: | Not cracked, broken, or loose; no missing bolts; mounted securely; proper tread and free of debris or foreign objects. |
| Battery/box: | Box/cover secured; no cracked, broken welds. Battery connectors secured; no ripped, torn, exposed, or corroded wires or cables. |
| Lights & reflectors: | Not cracked, broken, or loose; no missing lights; not covered; proper color. Not torn, loose, or covered; no missing reflectors. |

Under Vehicle

| | |
|-----------------|--|
| Drive shaft: | Not bent; no cracked, loose, or missing bolts; couplings are secure and greased; no obstruction around drive shaft. |
| Exhaust system: | Not cracked, broken, or rusted through; no signs of soot lines (cracks); no loose mounts. |
| Frame: | Frame is straight; not bent, twisted, or cracked; not rusted through; not sagging including cross beams & members; no illegal welds. |

Rear Axles

| | |
|--------------------------|--|
| Tires: | 2/32 min. tread; no cracks or cuts in side; not mismatched or unevenly worn; proper inflation with a gauge or mallet. No bulging; valve stem not cracked or cap missing. |
| Rims: | Not bent, cracked, or welded; not warped. |
| Lug nuts: | Not cracked, loose, or missing; no gaps, shiny threads, or rust trails. |
| Hub oil seal: | Not cracked or leaking; no loose bolts; proper level of oil. |
| Spacers or budd spacing: | Check for even spacing between wheels; not rubbing; no foreign objects. |

Rear Suspension

| | |
|-----------------------------|--|
| Spring & shocks & air bags: | <u>Springs</u> : Not cracked, broken, or loose; no missing <u>springs</u> . <u>Shocks</u> : Not cracked, bent, or loose; no leaking <u>shocks</u> ; no torn bushings. <u>Air bags</u> : No cracked, or leaking <u>air bags</u> ; not bulging or torn; same inflation on both air bags. |
| U-bolts: | Not cracked, bent, or broken; no loose or missing u-bolts; no missing nuts. |
| Spring/air mounts: | Not bent, cracked, or broken; no loose <u>air mounts</u> , or missing bolts. Not bent, cracked, or broken; no loose <u>spring mounts</u> , or missing bolts; no torn bushings on spring mounts. |

Rear Brakes

| | |
|----------------------------|--|
| Brake hoses or lines: | No cracked, worn, or leaking air hoses; fitting are tight; lines are not cracked, loose, or rubbing on anything; no exposed or corroded wires. |
| Brake chamber: | Not cracked, dented, or loose; no missing bolts or broken c-clamps; not leaking air. |
| Slack adjustor & Push-rod: | Explain: "I would first chock the tires, and release the parking brake; and then check for not more than 1 inch of play, when you pull by hand." Not bent or cracked; no missing pins or cotter keys; properly greased. |
| Drums: | No warped, cracked, or welded drums; no grease or oil. Look through inspection hole (automatic only): linings are not cracked; no grease or oil on them; evenly worn. |
| Linings: | Linings (shoes) are at least 1/4 inch thick, evenly worn. |

Rear of Vehicle

| | |
|----------------------|---|
| Splash guards: | Not cracked, broken, or loose; no missing bolts; mounted secure; proper height. |
| Lights & reflectors: | Not cracked, broken, or loose; no missing lights; not covered; proper color. Not torn, loose, or covered; no missing reflectors; no loose wires. |

Combination Vehicles

Trailer Front

- Header board: Not bent, twisted, or loose; no cracked or broken welds.
(Strong enough to contain cargo.)
- Lights & reflectors: Not cracked, broken, or loose; no missing lights; not covered; proper color.
Not torn, loose, or covered; no missing reflectors.

Side of Trailer

- Landing gear: Fully raised up off ground; no missing or loose bolts; no cracked welds.
Handle is secure.
- Frame: Frame and cross members are straight, not bent, twisted, or cracked; not rusted through; not sagging; no broken welds.
- Ties: Not cracked or bent, or missing; no broken welds.
- Lights & reflectors: Not cracked, broken, or loose; no missing lights; not covered; proper color.
Not torn, loose, or covered; no missing reflectors.

Trailer Wheels

- Tires: 2/32 min. tread; no cracks or cuts in side; not mismatched or unevenly worn; proper inflation with a gauge or mallet; no bulging; valve stem not cracked or cap missing.
- Rims: Not bent, cracked, or welded; not warped.
- Lug nuts: Not cracked, loose, or missing; no gaps, shiny threads, or rust trails.
- Hub oil seal: Not cracked or leaking; no loose bolts; proper level of oil.

Trailer Suspension

- Springs: Not cracked, broken, or loose springs; not cracked, bent, or loose.
- U-bolts: Not cracked, bent, or broken; no loose u-bolts; no missing nuts.
- Spring mounts: Not bent, cracked, or broken; no loose mounts, or missing bolts; no torn bushings.

Trailer Brakes

- Brake hoses or lines: Not cracked, worn, or leaking air hoses; fittings are tight.
ABS lines are not cracked, loose, or rubbing on anything. No exposed wires or corrosion.
- Brake chamber: Not cracked, dented, or loose; no missing bolts or broken c-clamps; not leaking air.
- Slack adjuster & Push-rod: Not bent or cracked; no missing pins or cotter keys; greased.
No more than 1 inch of play when you pull by hand. Also, not bent or cracked.
Explain: "I would chock my tires and release the trailer parking brake to check for more than 1 inch of play on the push rod when I pull by hand."
- Drums: No warped, cracked, or welded drums; no grease or oil.
Look through inspection hole (automatic only): linings are not cracked; no grease or oil on them.
- Linings: Linings are at least 1/4 inch thick; evenly worn.

Rear of Trailer

- Loading Ramps: Not cracked, broken, or loose; no missing bolts; mounted secure; no broken welds; no missing pins. Upright position.
- Splash guards: Not cracked, broken, or loose; no missing bolts; mounted secure; proper height.
- Lights & reflectors: Not cracked, broken, or loose; no missing lights; not covered; proper color.
Not torn, loose, or covered; no missing reflectors.

(Now close the hood, turn the key on, and start checking all your lights):

Right turn signal: Get out and check front & back;
Left turn signal: Check front & back;
Flasher: Check front & back;
Brake Lights: Ask the examiner to help you check the brake lights.
Low Beams: Check front;
High Beams: Check front;
Running Lights: Check all sides of truck and trailer and top of cab.

INSIDE VEHICLE

Safety belt: Belt is securely mounted; not torn or frayed; adjusts and latches/unlatches properly.
Emergency equip.: Spare fuses; 3 reflective triangles; properly charged and mounted secured fire extinguisher.
Safe start: Say: "Before I start the truck, I will make sure the parking brake is on and the transmission is in neutral." Then start the truck.
Temperature gauge: Point to it and say: "The temperature gauge is working and slowly rising."
Oil pressure gauge: Point to it and say: "The oil pressure gauge is working and shows oil pressure."
Voltmeter gauge: Point to it and say: "The voltmeter gauge is working and reading about 14 and is charging."
Air gauge: Point to it and say: "The air gauge is working and reading above 90 and holding air pressure."
Lighting indicators: Turn on and check both inside turn signal indicators and flashers.
Turn on head lights and check the high beam indicator.
Horn: Toot the horns.
Heater & defroster: Turn on the fan and test (twist) the heater/defroster controls to see if it works.
Windshield & mirrors: Windshield is clean, clear, and not cracked.
The mirrors are clean, clear, and adjusted properly.
Wipers & washers: The wiper blades are not cracked or missing and operate smoothly.
Test the washer fluid.
Parking brake: Release trailer brake (red valve) leaving yellow valve applied and put the truck in drive. Gently pull against the parking brake; truck should not move; "Parking brake works."
Service brake: Release all parking brakes, put the truck in drive, roll forward and stop with service brake (brake pedal); "Service brake works and also brakes evenly apply without pulling to either side."

***AIR BRAKE CHECK*:** (leave both the parking brakes in, and keep your foot on the brake pedal)

1.) Air Loss check: Put the truck in neutral, **turn off the truck** but turn the key back to the ON position; Both parking brake valves should be released. Explain: "I should not lose more than 4 psi per minute." (3 psi for class B.) Wait the full minute while holding the service brakes.

2.) Low Air Alarm check: Explain: "The Low Air Alarm should come on between 80 - 60 psi." Start to pump the brakes slowly until alarm sounds. Explain: "Alarms work. Both visible and audible."

3.) Emergency Brake check: Both parking brake valves should still be pushed in and released at this time. Explain: "Both valves should pop out and apply automatically between 40 - 20 psi." Start to pump the brakes until both valves apply. Immediately start the engine, put the truck in drive and try to pull against the brakes. Explain: "Emergency brakes hold." Put the truck in neutral and build air pressure to at least 90 psi.

Before you leave the curb, be sure to check the trailer connection.

Check trailer connection: Release yellow parking brake valve (push in) and leave red trailer brake valve applied (pulled out). Gently pull truck forward to show hitch is securely locked and coupled together. Explain, "Trailer is connected securely."

Make sure you point out and give a detailed description/explanation about each & every item listed!

In short, try to give a 3 - 4 point description about nearly every item listed.

- Examples”
- “not cracked, broken, or loose”
 - “no missing bolts; mounted securely”
 - “not bent, twisted, or warped; not rusted through”
 - “not leaking” etc.

Follow the list, and Be mindful of what you are saying.

Arrive at the Driver’s Exam Station at least 30-45 min. before your scheduled road test.

Check in at the Outside Dispatch Window.

Wait in or by your CDL Test Truck.

Review your pre-trip.

Mentally Prepare for you road test:

- | | | | |
|-------------------------|-----------|--------|--------------|
| Proper Turns: | Right. | Left. | Double Left. |
| Proper Stops. | | | |
| Proper Observation. | | | |
| Proper Hill Park. | | | |
| Backing: | Straight. | Alley. | Off set. |
| Proper Highway Driving. | | | |

Directions from our Practice Lot:

- Take a right at the stop sign.
- Take a right at the next stop sign (Airport Rd.)

- Go East on Hwy. 10 (about 1.5 miles)
- Follow 35W South (about 1/4 mil.)
- Take the first exit County Rd. I, and go right at the bottom of ramp.
- Take a right on first service road (look for Big Green Sign saying Driver Exam Station).

Eric’s Cell Numbers: 612-618-1812
612-723-4398

HELPFUL ACRONYMS:

CCC = No **C**racks, **C**lean, **C**lear

CDL = No **C**racks/Cuts, **D**ents, **L**eaks/Loose

ABC = No **A**brasions, **B**ulges, **C**racks/Cuts

PMS = **P**roperly **M**ounted, **S**ecure

Class A Leasing Office Address

8899 Hastings St. NE
Blaine, MN 55449

Arden Hills Exam Station Address

5400 Old Highway 8
Arden Hills, MN 55112

Plymouth Exam Station Address

2455 Fernbrook Lane N
Plymouth, MN 55442

CDL Appointments for Plymouth and Arden Hills: 651-297-5029